

DETAIL D
MABSTAB 1.5 : 1

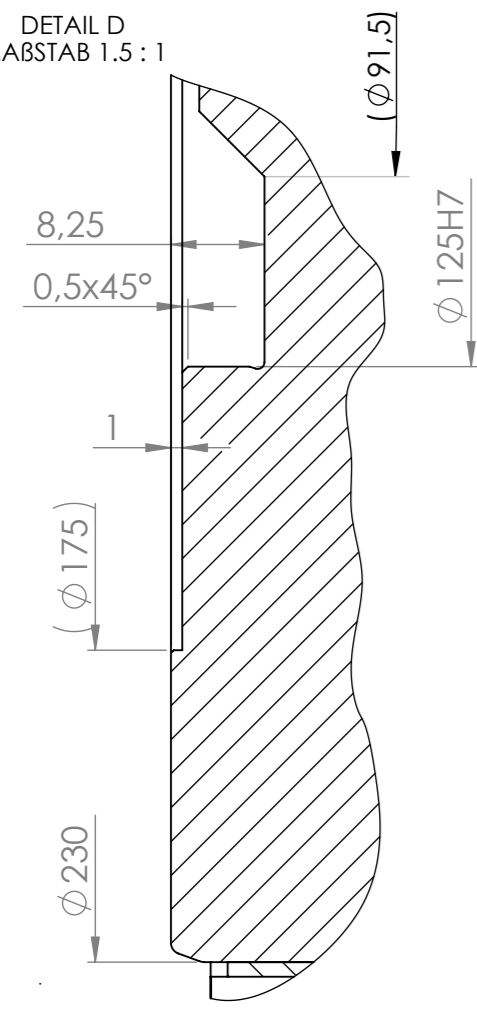

DETAIL B
MABSTAB 1 : 1

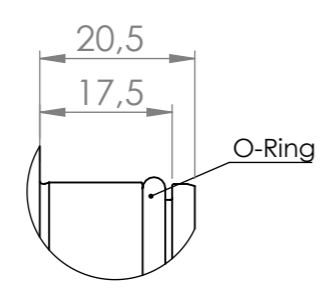

DETAIL C
MABSTAB 1 : 1

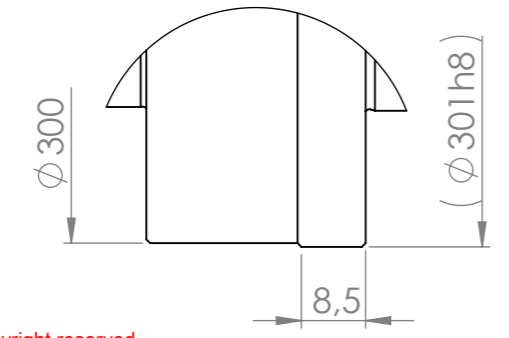

SCHNITT A-A
MABSTAB 1 : 1

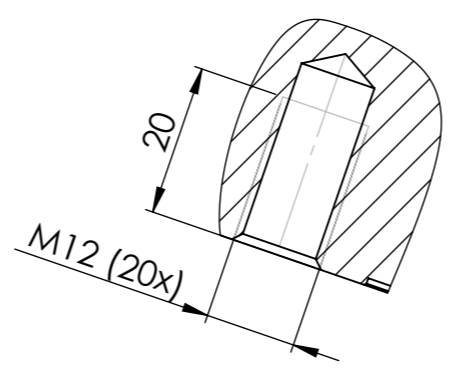

SCHNITT E-E
MABSTAB 1 : 1

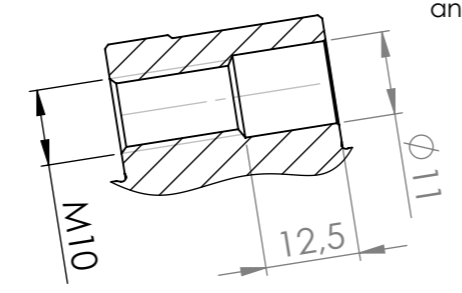

4x für Handhabung
und Demontage
4x for handling
and dismantling

				Datum	Name	Maßstab	Teile-Nr.		
				gez.	10.04.2017	KB	Scale	1:4	Part. No.
				gepr.	10.04.2017	FK	Werkstoff		Material
				Konstr.	10.04.2017	FK	Halbzeug		Masse
				Prod.T.	10.04.2017		Rohteil-Nr.		Mass
				Qual.S.	10.04.2017		Benennung		Title
				Mont.	10.04.2017				
Idx	Änderungs-Nr.	Datum	Name	C A D					
Oberfläche-Surface DIN ISO 1302				PREMIUM STEPHAN					
Allgemeintoleranzen General Tolerances				ISO 2768-mK					
Werkstückkanten DIN6784				Datei					
Edges of working parts				File 300V-KS3-SM-00					
				Ers.f.		Ers.d.			
				Repl.		Repl. by			
							PSC300V		
							Einbausatz Vollwelle - KS3		
							Zeichnungs-Nr.		Drwg.No.
							C0300-006-3A00		Blatt-Page
									1 / 1